

OIL PURIFIER AGAINST WATER, GAS & PARTICLE CONTAMINATIONS

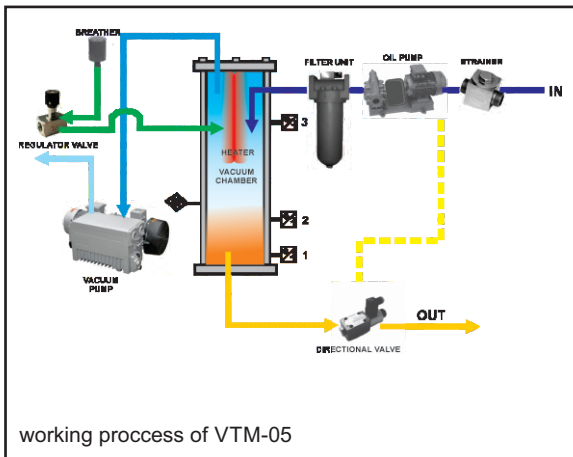

working process of VTM-05

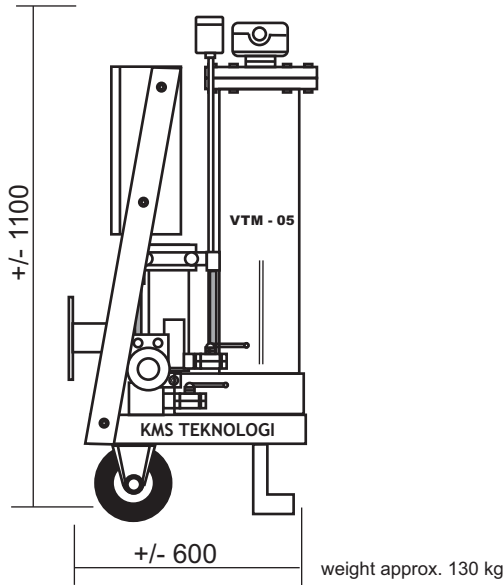
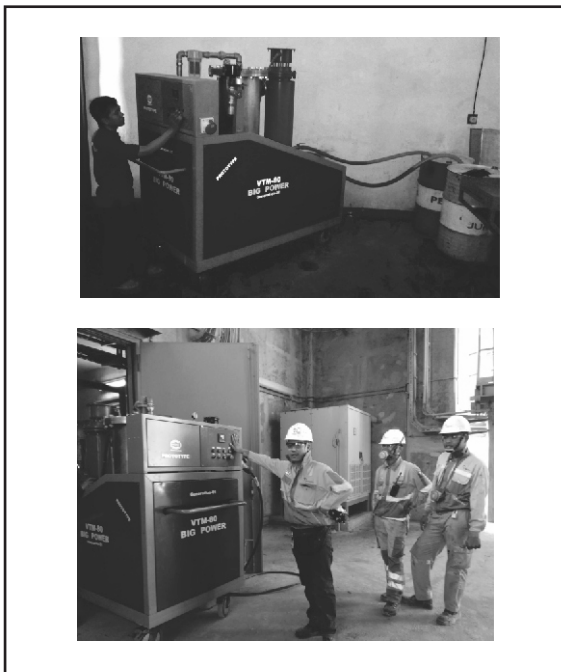

usages of purifier (VTM-80) KMS TEKNOLOGI® at our customers

VTM-05 SERIES
VACUUM TECHNOLOGY
OIL PURIFIER

Basic Model

VTM - 05 - M - 400 - H - MS - X

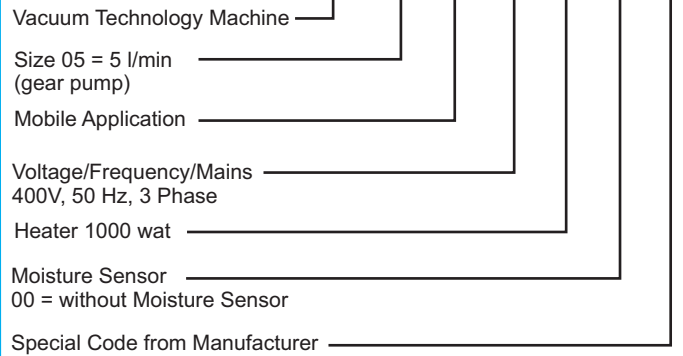

VTM-05 Series operates on the principle of vacuum technology to eliminate free and dissolved water as well as free and dissolved gases, also particle contamination from hydraulic and lubrication fluids. Equipped with a heater to work for high viscosity oil. Optional tool, have a water sensor for continuous monitoring of the water content and for controlling the unit. Programmable logic control, guarantees simple and reliable operation.

Advantages

1. Extremely lower residual water levels, gas levels & particle contamination in fluid operation mineral oil (for synthetic, use FKM)
2. Longer oil change intervals
3. Improved component service life
4. Made in Indonesia, to make sure a competitive price, quick services & ready stock spare parts

Specifications :

1. Flow rate @50Hz : 5 l/min
2. Operation viscosity range 15 - 550 mm2/sec (with integrated heater)
3. Electrical power consumption +/- 2,5 kW (with heater)
4. Power supply 400V, 3 phase, 50 Hz
5. Mobile applications
6. Equipped with pressure filter & strainer filter
7. Gear pump 5 l/min, 10 bar
8. Rotary vacuum pump
9. Inlet 2" - Outlet 1.5"
11. Other flow rate contact KMS TEKNOLOGI®

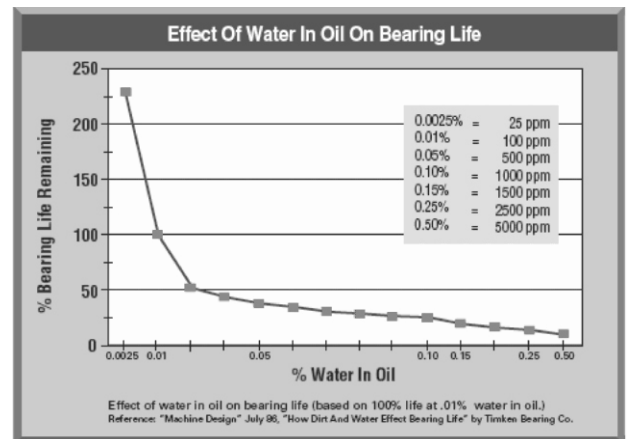

distributor :