

OIL PURIFIER AGAINST WATER, GAS & PARTICLE CONTAMINATIONS

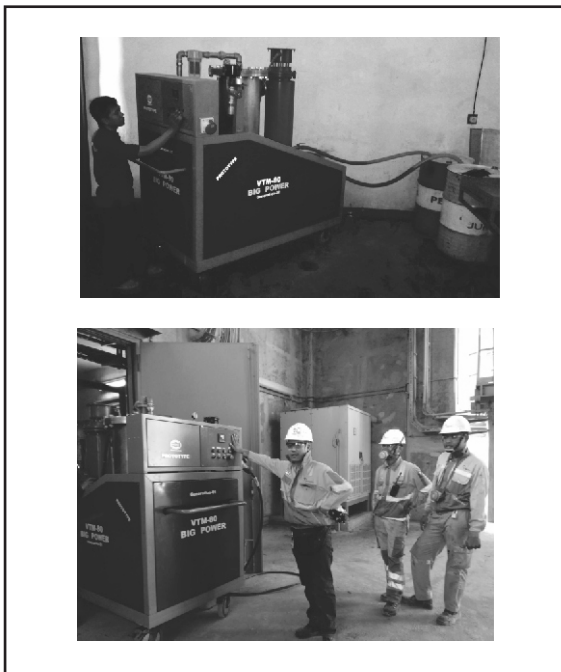
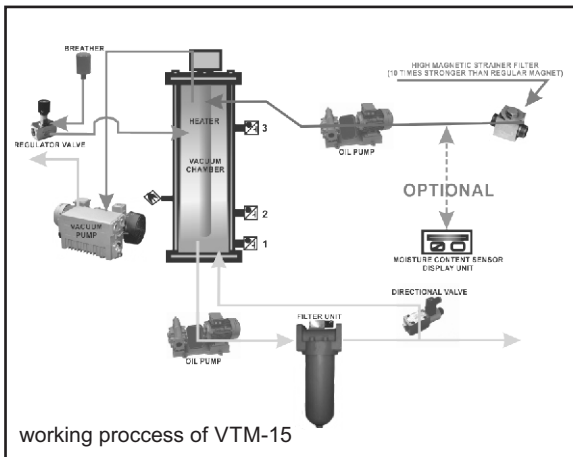
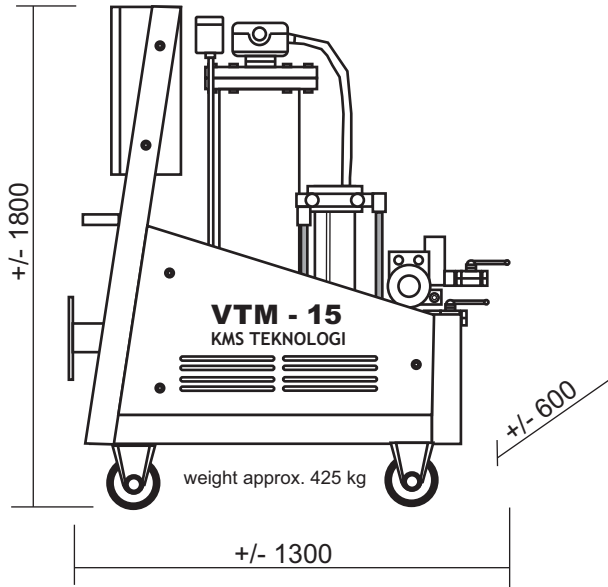

usages of purifier KMS TEKNOLOGI at our customers

**VTM-15 SERIES
VACUUM TECHNOLOGY
OIL PURIFIER**

Basic Model

VTM - 15 - M - 400 - H - MS - X

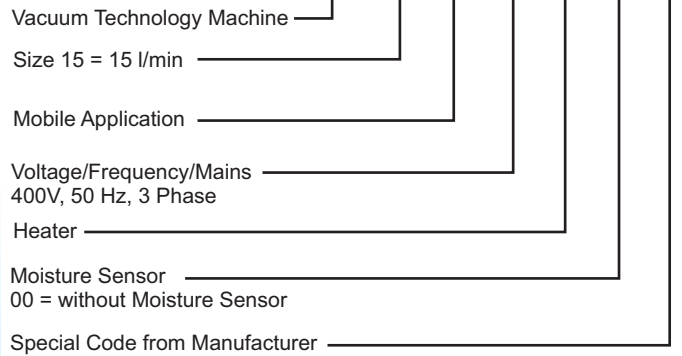

VTM-15 Series operates on the principle of vacuum technology to eliminate free and dissolved water as well as free and dissolved gases, also particle contamination from hydraulic and lubrication fluids. Equipped with a heater to work for high viscosity oil. Optional tool, have a water sensor for continuous monitoring of the water content and for controlling the unit. Programmable logic control, guarantees simple and reliable operation.

Advantages

1. Extremely lower residual water levels, gas levels & particle contamination in fluid operation (hydraulic & mineral oil)
2. Longer oil change intervals
3. Improved component service life
4. Strong Magnetic filter to catch metal particles
5. Made in Indonesia, to make sure a competitive price, quick services & ready stock spare parts

Specifications :

1. Flow rate @50Hz : 15 l/min
2. Operation viscosity range 15 - 500 mm²/sec
3. Electrical power consumption 10.5 kW (with heater)
4. Power supply 400V, 3 phase, 50 Hz
5. Mobile applications
6. Equipped with pressure filter & magnetic filter suction
7. Gear pump 15 l/min, 10 bar
8. Optional water sensor
9. Rotary vacuum pump
10. Inlet - Outlet 1"
11. Other flow rate contact KMS TEKNOLOGI

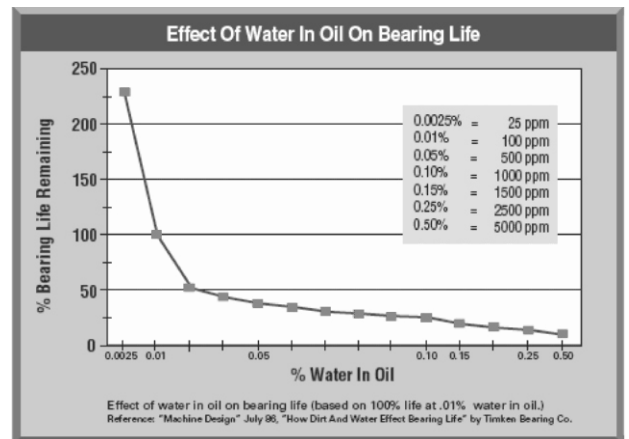

distributor :